

Multiblitz®



*The perfect
flash system
for professional
lighting control*

MINILITE 200

MINILITE 200

Work at home
like a studio
photographer —
Professional quality
illumination with the
MINILITE-SYSTEM

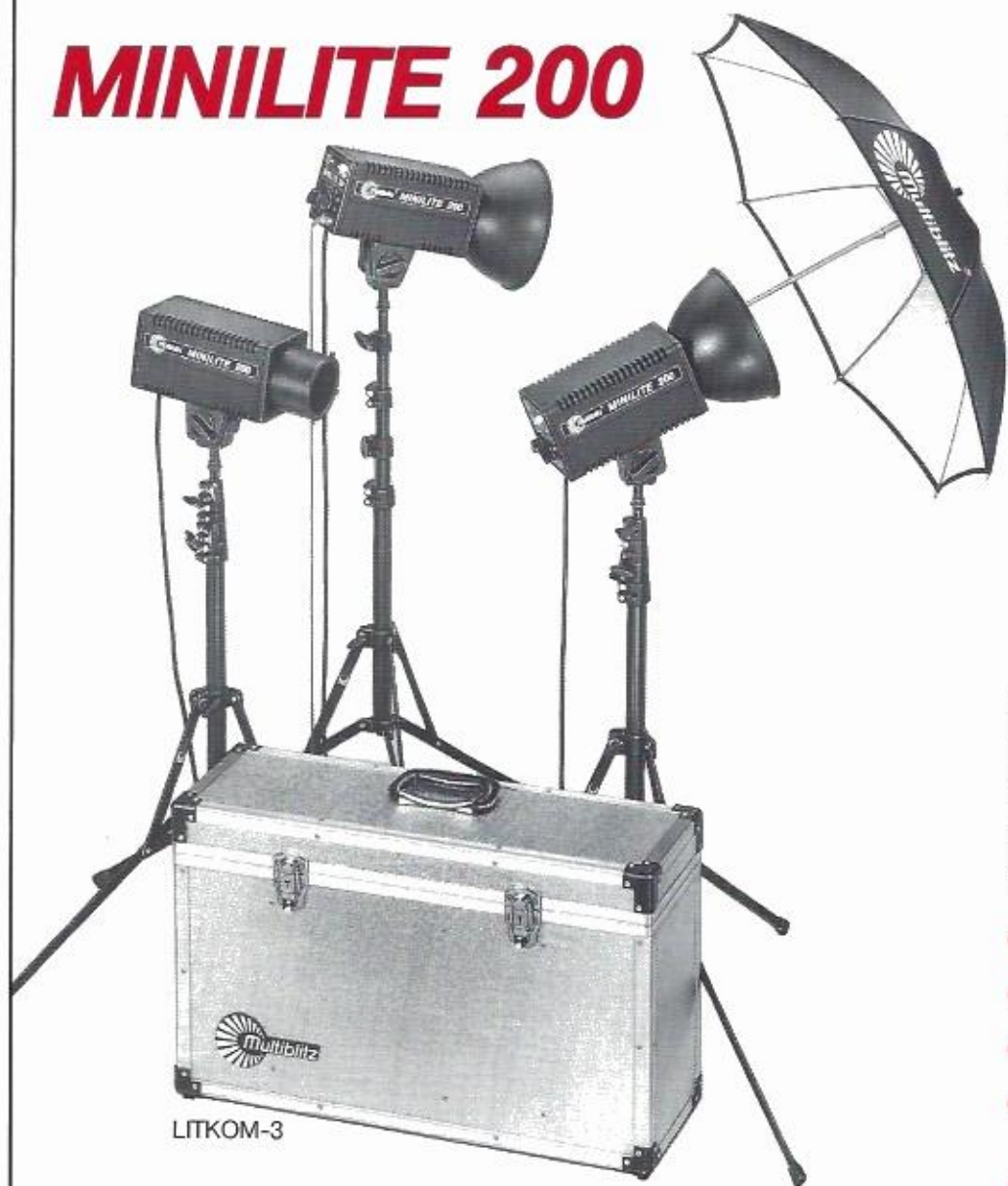

LITKOM-3

MINILITE-SYSTEM — A complete outfit all in case. Easy to carry, this stylish plastic case has compartments for the following items:

Two MINILITE 200, two standard reflectors, sync cords and spare fuses. There are also compartments for other accessories, such as the Effect light Set.



TRIKOM

LITKOM-2, version TRIKOM: 3 Minilite 200 units and 3 standard reflectors contained in plastic transport case. Version LITKOM-3: 3 Minilite 200 units, 3 stands, 2 standard reflectors, 1 umbrella reflector, 1 diffusor and 1 honeycomb grid in professional aluminium case.

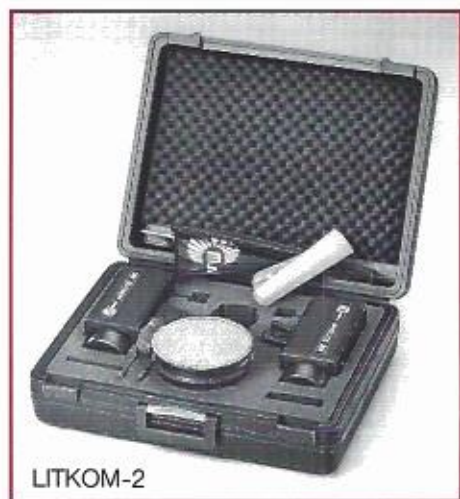

LITKOM-2

It is hard to imagine a professional studio today without the blessing of electronic flash incorporating interchangeable reflectors and modelling light. All the advantages of this type of modern, high-efficiency light source are now indisputable.

- Short flash duration for sharp exposures free of camera shake
- Stable colour characteristics during entire service life
- Low heat generation and good utilization of energy
- Quartz halogen modelling light for previewing balance of light and shade
- Interchangeable reflectors and accessories for precise control of lighting effects

All these advantages are made available to the ambitious amateur photographer in the form of the new MINILITE 200, a compact studio flash unit of excellent quality and reasonable price. Particularly close attention was paid to the last point. Modern methods of manufacture on a large scale kept costs down, and the result is a very favourable price/utility ratio for the photographer.

A sensible specification and a practical system of accessories leave plenty of scope for creative work with the MINILITE 200.

Indeed, one of the most fascinating aspects of photography in general is the personal control over the individual light sources.

Of course, technical safety, long service life, high light output and general ease of operation are considerations which every potential user should be able to take for granted.

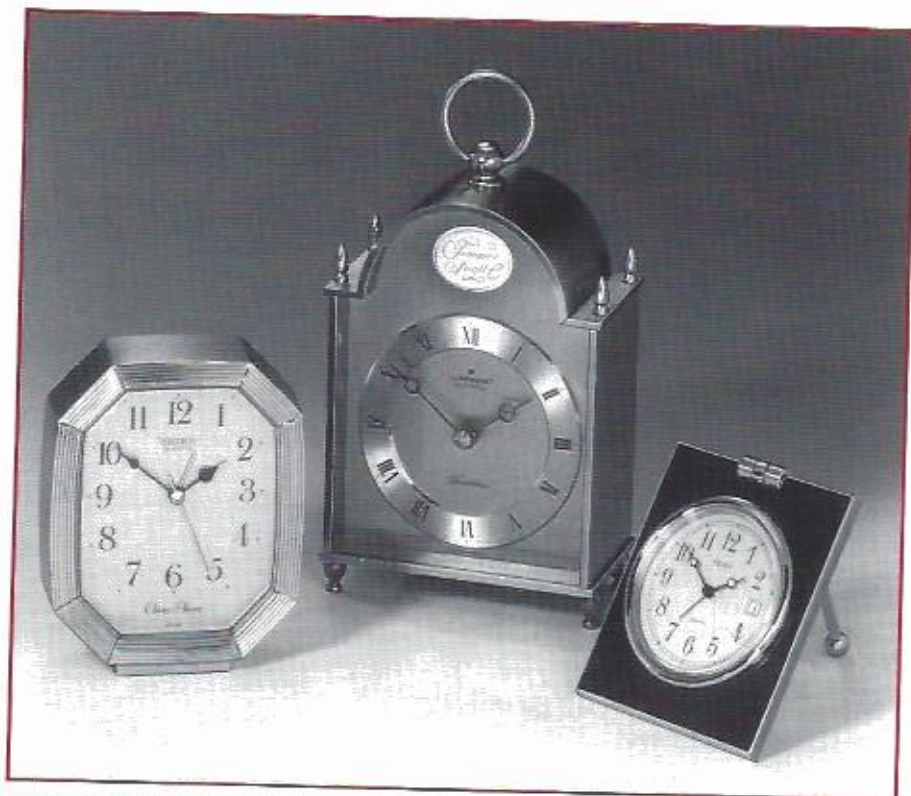

Example of product photograph: 3 clocks.

This was taken for a catalogue illustration in which text was to be superimposed later. The glass and metal surface had to be free of unwanted reflections. 5 Minilite 200 were used, 2 softboxes and 2 standard reflectors with diffusing screens. Snoot

from the rear for effect light. 2 standard reflectors for the powerful main light. Square reflectors were placed over the fill-in lights. Due to the high level of light, it was possible to use an aperture of f/45 on a 6x7 camera.

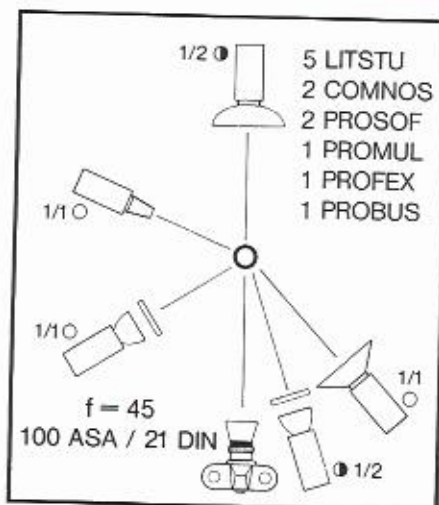
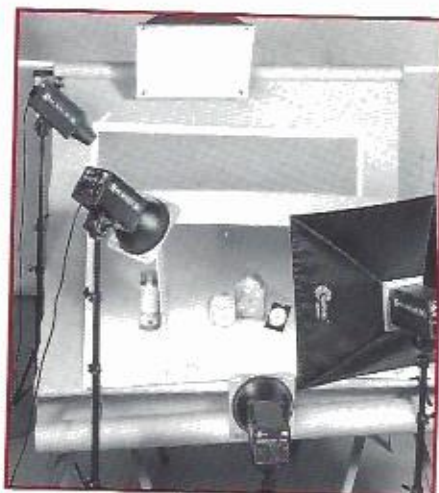

Wide range of accessories:

It is the extensive range of accessories, however, such as bounce-light umbrellas, reflector attachments and

colour filters, which turn the light source into a creative tool. Here we find evidence of the logical develop-

ment of the MINILITE system: the decades of experience invested by MULTIBLITZ in the construction of studio flash equipment become more than apparent.



Folding reflector MULTIFLEX 50: 50 x 50 cm PROFEX/MULTIFLEX 75, 75 x 75 cm, PROFEX-75. Square, collapsible reflector with fabric cover; ideal for location portraiture and product photography outside the studio.



The standard reflector COMNOS for maximum light reflection. 16 cm diam.; 65°-angle of emission. Can be fitted with the diffuser PROSOF and the barn doors PROKLA for further light control.



The square attachment MULTILITE 40, coated white inside and fitted with diffuser. To obtain a gradual transition from light to dark, the honeycomb grid PROWAL is recommended. The MULTILITE 40 is shown here with the barn-doors MULKLA.



Barn door attachment PROKLA for standard reflector COMNOS.



The honeycomb grid and the filter holder for colour gels: special colour effects for eye-catching photography. The 8-cm diam. honeycomb grid PROWAB can be used alone without the filter holder as a hairlight, etc. Common to all other accessory attachments/reflectors in the MINILITE system, the above grid is secured via a rapid-change bayonet mount.



Honeycomb grid PROWAN for standard reflector COMNOS. Concentrates beam in narrow cone.



Further interesting accessories for special applications: Barn doors PROKLA, snoot PROBUS, 8 cm diam. honeycomb grid PROWAB, filter

holder PROFIL, 16 cm diam. honeycomb grid PROWAN, set of colour filters (5) PROFIZ.



The umbrella PRORES, 70 cm diam., coated white inside. The ideal arrangement for soft, large-area illumination, e.g., for a standing figure. Used together with the standard reflector.



Set off collapsible stands in transport case: 2 stands = STASET, 3 stands = TRISSET.



a name known around the world for performance and quality

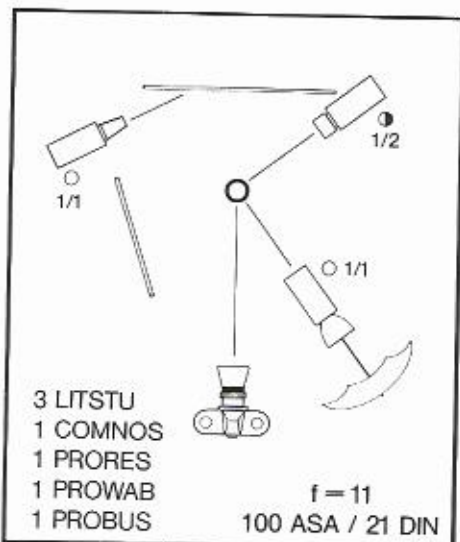
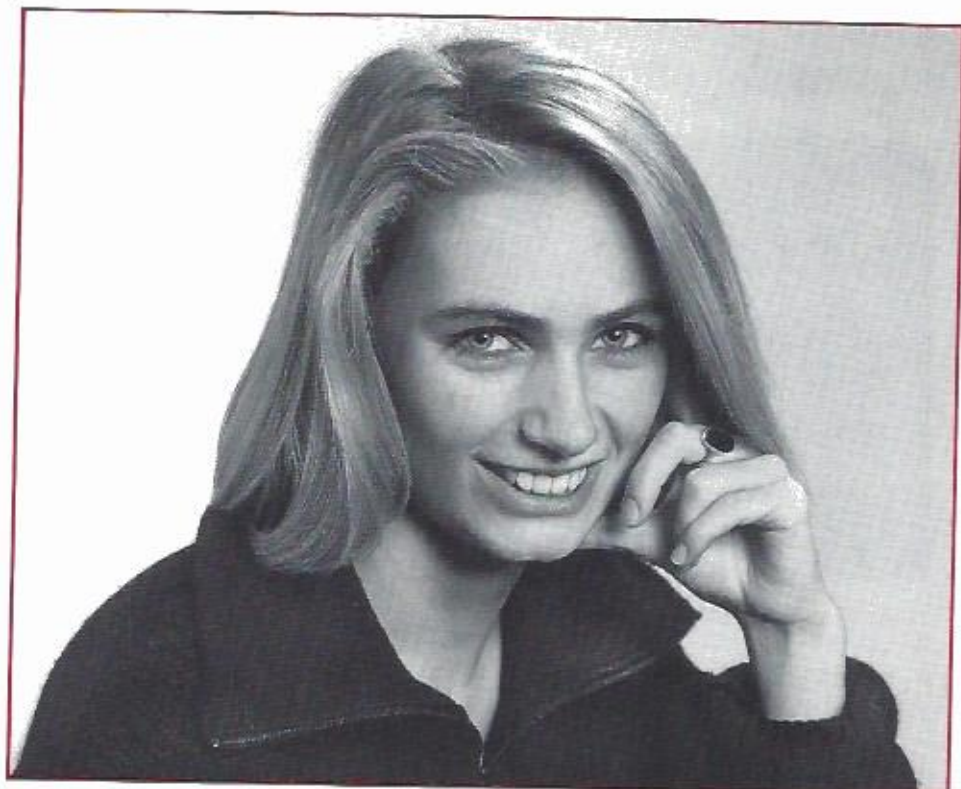

Portrait arrangement:

Here we see the virtues of the MINILITE 200: a fresh portrait in up-to-date style, a moment captured from life. Soft, flattering main light via the umbrella, sharp effect light on the hair with honeycomb grid plus a further lamp fitted with snoot for the background. Fill-in light bounced

via folding reflector RONDOFLEX-SILVER. The result: not a stiff, hold-it pose but a natural expression – thanks to the high speed of the flash. The actual exposure, measured with the aid of a Calcu-flash S, was $f/8-11$ with a shutter speed of $1/2$ sec.

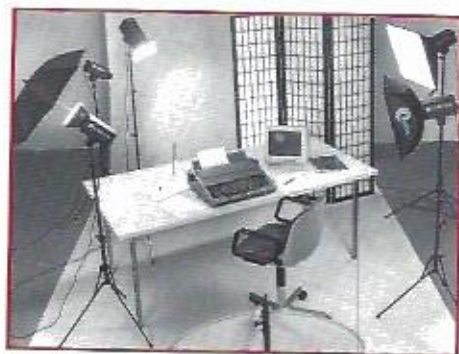

Example of an interior: office desk.

Lighting arrangement in keeping with products using 4 Minilite 200 fitted with both square and standard reflectors. Background and screen illuminated by 2 further Minilite 200 units. By virtue of

careful positioning of the two units – fitted with square reflectors as the main source – a natural effect was obtained.

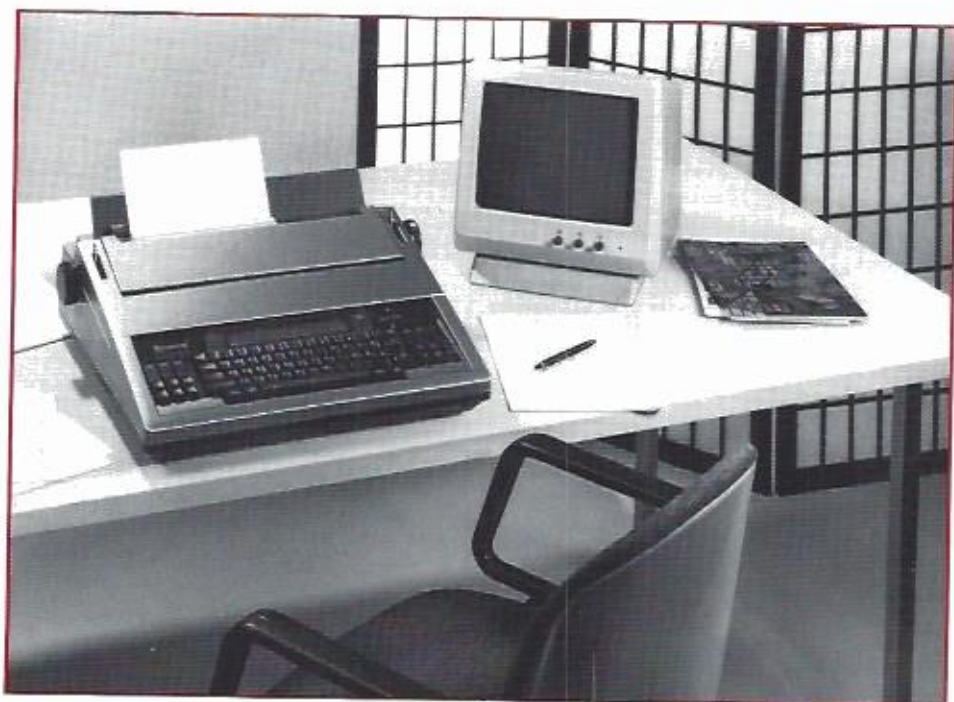
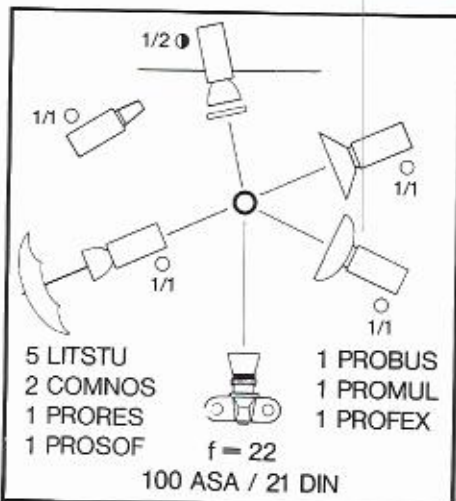

Easy to operate and plenty of power —
successful photography right from the start.

Multiblitz®
MINILITE 200



Operating controls:

- ON/OFF switch for flash and modelling light
- Step-down switch for full or half power - with/without modelling light
- Built-in slave cell with adjustable cap
- Manual release
- Sync cable socket
- LED „ready” indicator
- Power supply cable permanently attached

Technical specification:

Power setting	1/1	1/2
Guide No. for 100 ASA/21 DIN with standard reflector	50	36
12 V halogen lamp, proportional to flash	50 W	25 W
Flash recycling time, indication at 100% charge	2,8 sec.	1,9 sec.
Flash duration at t 0,3	1/400 sec.	1/600 sec.
UV-corrected flash tube	5600 K	
Mains voltage	220/50-60 Hz	
Consumption rating	150 W	
Dimensions incl. protective cap and tilting base	23 x 10 x 15 cm	
Weight	2kg	

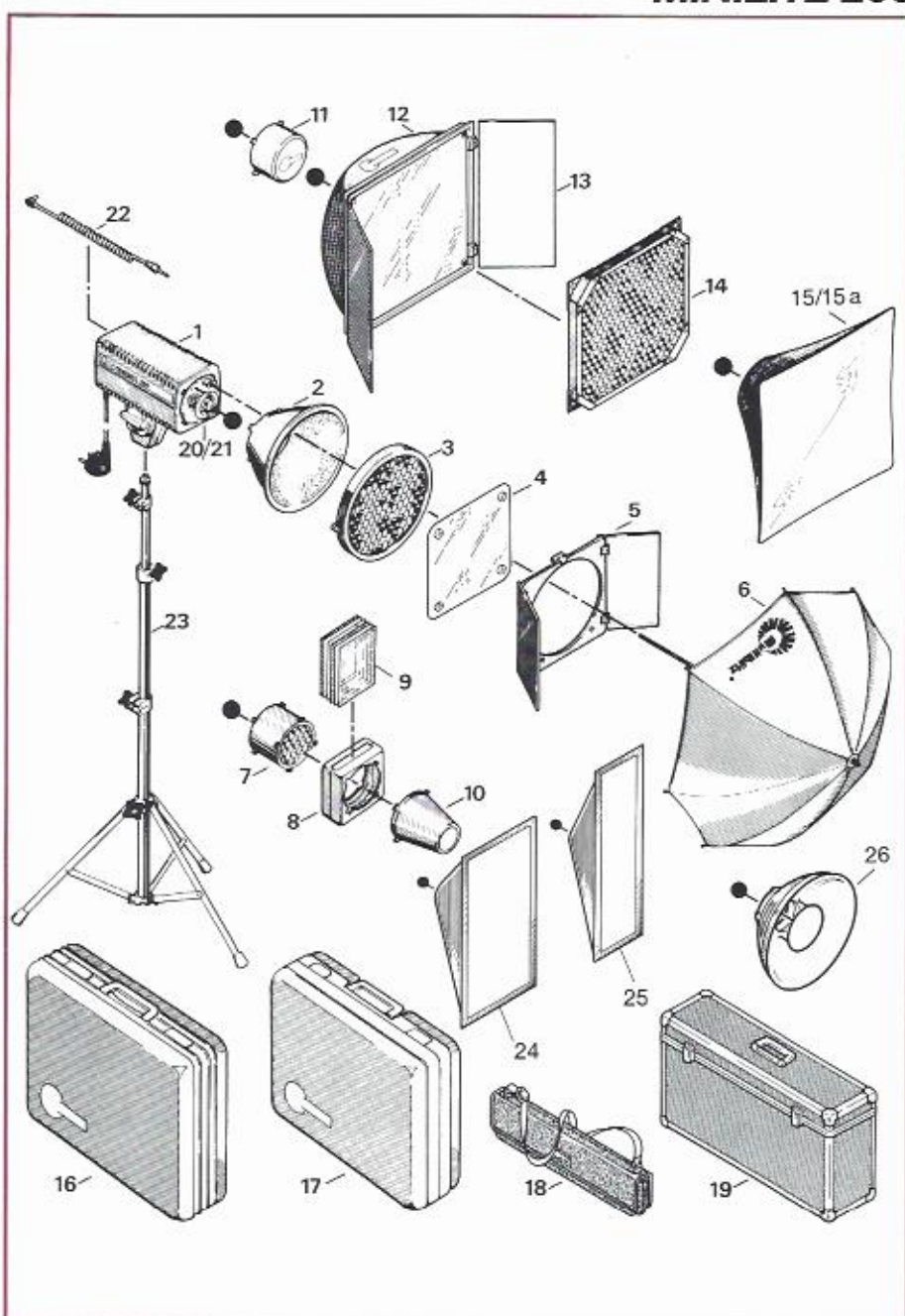

Your dealer:

The Minilite 200 System Accessories

- | | | |
|----------|---------------|--------------|
| 1 LITSTU | 10 PROBUS | 18 STABAG |
| 2 COMNOS | 11 PROKAP | 19 PROALT |
| 3 PROWAN | 12 PROMUL | 20 LITROW |
| 4 PROSOF | 13 MULSAB-40 | 21 MIJOD |
| 5 PROKLA | 14 PROWAL | 22 MASYS |
| 6 PRORES | 15 PROFEX-50 | 23 MA 060 |
| 7 PROWAB | 15a PROFEX-75 | 24 PROREC-40 |
| 8 PROFIL | 16 LITTRA-2 | 25 PRORIP-25 |
| 9 PROFIZ | 17 LITTRA-3 | 26 COMWEW |



Multiblitz Dr. Ing D. A. Mannesmann GmbH & Co KG
D-5000 Köln 90 · Ferdinand-Porsche-Straße 19 · Telefon: 0 22 03 / 30 09-0
Telex 8874 490 · Telefax 0 22 03 / 30 09 33